

SA5(1-12), SA5(2-11), SA5(3-10) - Config Speed UART for NV08C-CSM
 SA5(4-9) - PPS out for user '0' Enable, '1' Disable
 SA5(5-8), SA5(6-7) - Work RS232 or MCU

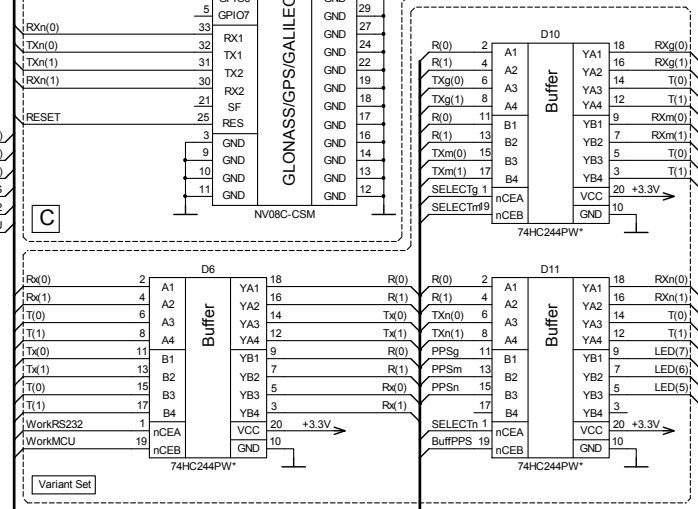
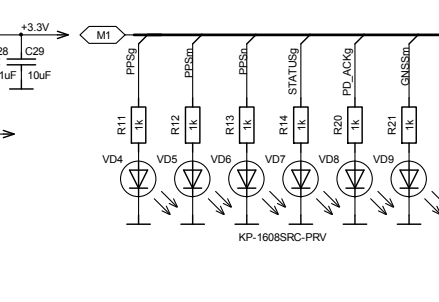
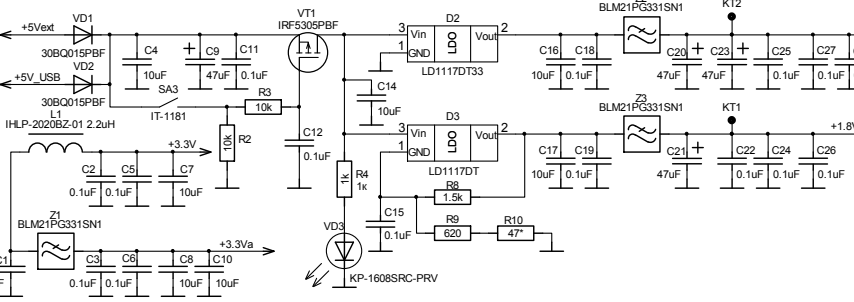

LDM-HELPER-NM ver.1.02			
Изм. Лист	№ докум.	Подп.	Дата
Разраб.	LDM-SYSTEMS		12.03.16
Пров.	LDM-SYSTEMS		
Нач.лаб.	LDM-SYSTEMS		
Гл.конст.	LDM-SYSTEMS		
Н. контр.	LDM-SYSTEMS		
Утв.	LDM-SYSTEMS		

Slave Module

Лит.	Масса	Масштаб
Лист	Листов	

LDM-SYSTEMS

Изм. № докл. Подп. и дата Инв. № докл. Подп. и дата Сдана. № Инв. № докл. Подп. и дата Первая примен. LDM-HELPER